



# VARODRY

Dry Screw Vacuum Pumps

Vacuum can be so...

**easy** reliable  
**efficient**  
**dry**



# Vacuum can be so...



## ...easy

### OPTIMIZE SIMPLICITY

- Effortless installation - just connect to power
- Fully air-cooled, no need for cooling water
- Compact design, seamless integration or retrofit



## ...efficient

### MINIMIZED TOTAL COST OF OWNERSHIP

- Low upfront investment and operating costs
- Best-in-class power consumption
- Limited maintenance expenses
- No costs for cooling water and compressed air
- Quiet, low pitch sound level
- Excellent condensable vapor pumping capacity



## ...dry

### 100% CLEAN VACUUM

- True oil-free vacuum pump
- Absolutely no oil needed, not even for gear-box lubrication
- Free of any oil emissions or oil leakages
- No oil migration into vacuum chamber or product



## ...reliable

### OPTIMIZE SYSTEM UPTIME

- Robust pump design, made for industrial applications
- Uses only proven and simple machine parts
- Superior performance, even in humid and dusty applications
- Tested under extreme conditions
- Extended maintenance intervals
- Long-term operation without system downtimes

Utilizing the best today's technology has to offer.

easy efficient reliable  
dry

### Intake connection

- Horizontal or vertical orientation
- G-thread as standard
- ISO-KF, ISO-K or NPT thread as accessory

### Exhaust connection

- G-thread as standard
- ISO-KF or NPT thread as accessory
- At lowest position, enabling condensate drainage

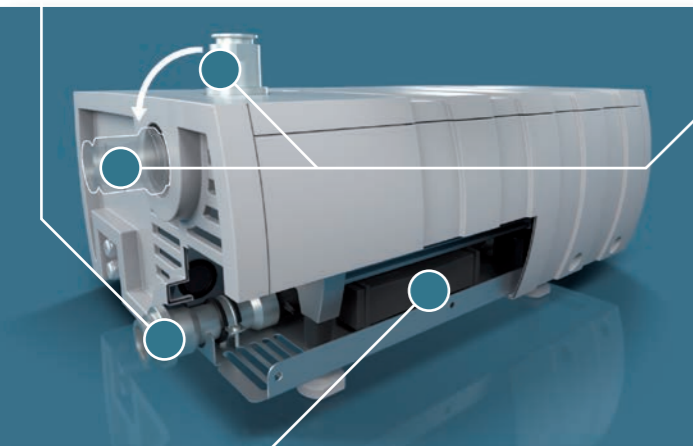

### Build-in exhaust silencer

- No extra installation space for silencer
- Lowest noise emission
- Drainable design

### Variable pitch rotor

- Benchmark efficiency
- Lowest power demand in its class

### Shaft seal / bearing protection

- "Self-cleaning" seal design
- Optional purge-gas system available
- No need for seal purge in most industrial applications

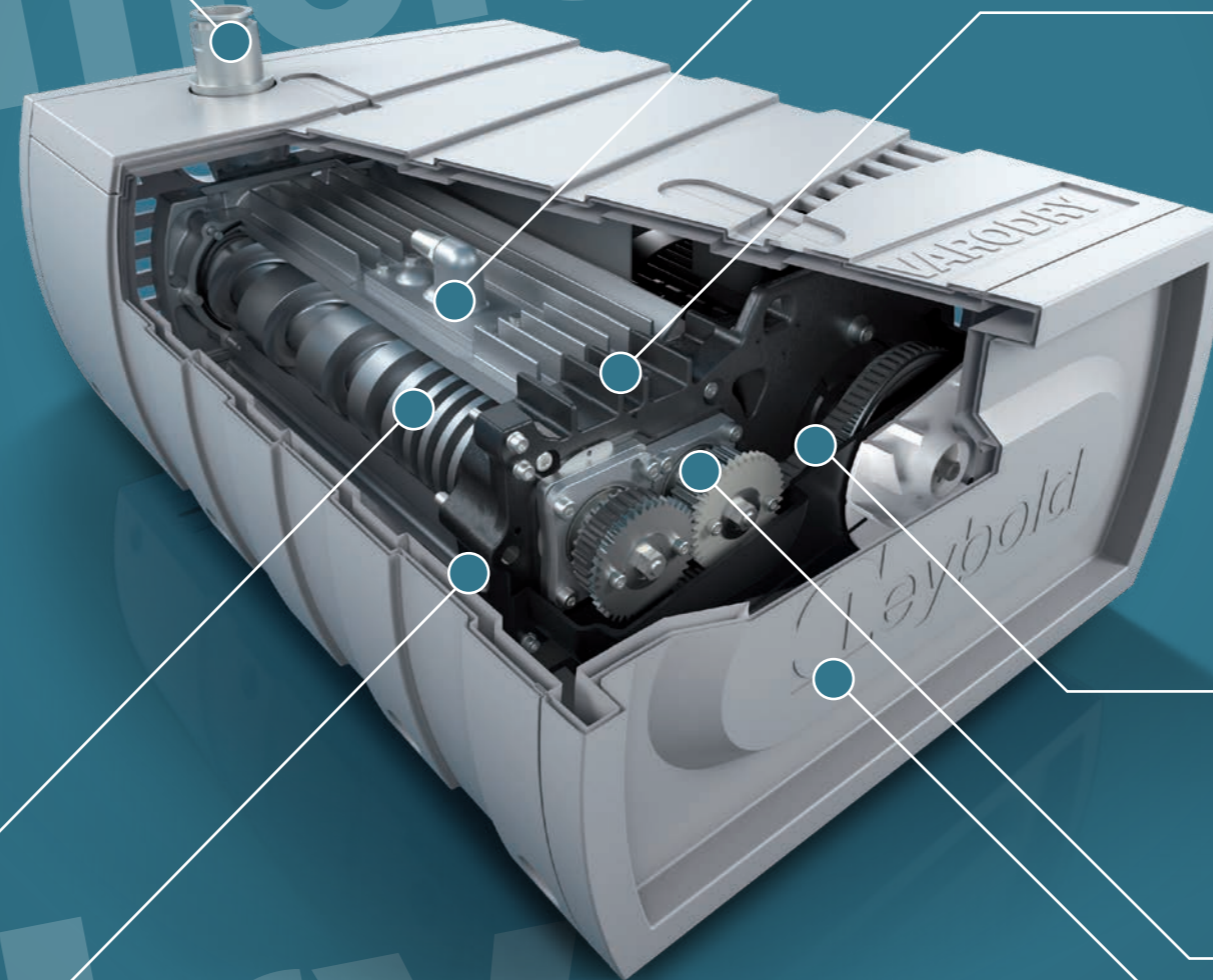

### Gas-Ballast

- High vapor tolerance
- Supports dust handling

### Air-cooled design

- Low operation cost
- Simple integration into mobile system

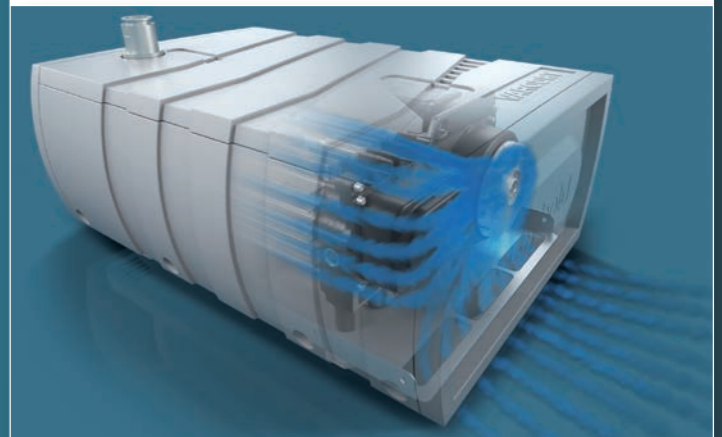

### High-tech belt-drive

- Provides synchronization and transmission
- Proven, long-life technology
- Easy to maintain
- No need for gear lubrication

### Innovative bearing technology

- Most robust hybrid bearing design
- Life-time grease lubricated
- No need for oil exchange

### Enclosure

- Integrated noise dampening
- Enhances pump integrity
- Clean and sleek design

# VARODRY

easy - efficient - reliable - dry

Eliminate process inefficiencies caused by vacuum.



The new VARODRY vacuum pump series is designed and produced by Leybold, in Germany specifically for industrial processes. Give yourself one less headache, with VARODRY vacuum can be easy, efficient, reliable and dry.

*“Our motivation was to develop the most energy efficient industrial dry pump!”*

Dirk Schiller, Head of engineering

### Efficient pumping

The VARODRY rotor design is optimized to provide best-in-class efficiency.

### Pumping speed

The VARODRY provides a competitive pumping speed over the complete pressure range and a low end-pressure of < 0.01 mbar. It can operate continuously at any inlet pressure.

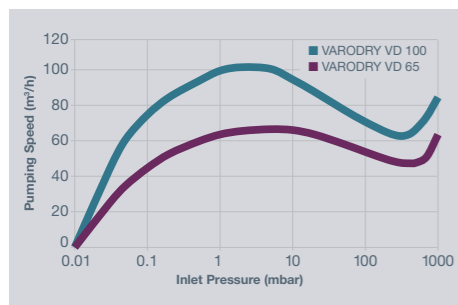

### Pump-down time (100 l chamber)

The VARODRY provides fast pump-down to the 10<sup>-2</sup> mbar range.

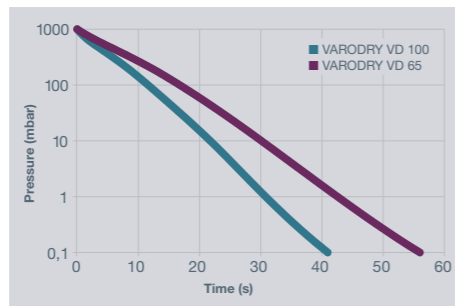

### Power efficiency index

The effective pumping speed generated per consumed power is a market benchmark for industrial dry pumps.

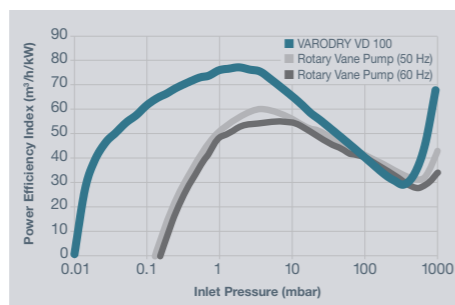

The VARODRY is optimized for the challenges found in many industrial applications:

#### Repeated and fast cycling:

The VARODRY offers very quick pump down. The pump tolerates atmospheric pressure shocks and repeated evacuation cycles.

#### Dust / particle handling:

The pumps screw principle offers best performance to handle fine, dry dust particles without wear. A wide portfolio of dust filters are available if big dust amounts need to be handled.

#### Vapor handling:

Due to its optimized temperature profile and the built-in gas-ballast, the VARODRY offers a high vapor tolerance, avoiding internal condensation and corrosion.

#### Reactive gas handling:

Often vapors (e.g. hydrocarbons) tend to react inside hot dry pumps and build-up internal coatings which can cause pump seizing. The moderate temperatures inside the VARODRY virtually eliminate this risk.

#### Liquid handling:

The VARODRY can handle droplets or even liquid slugs as the liquids can flow freely out of the pump.

Simple parts,  
less maintenance

Improve the efficiency of your machines. VARODRY makes it easy.

### Operation costs

Being 100% air-cooled and dry, the VARODRY only consumes electricity, with no extra costs for cooling water supply or oil / oil-filter exchange and disposal. Its low power consumption will save significant operation costs.

### Cost of Ownership Example: Composites (wind power plant)

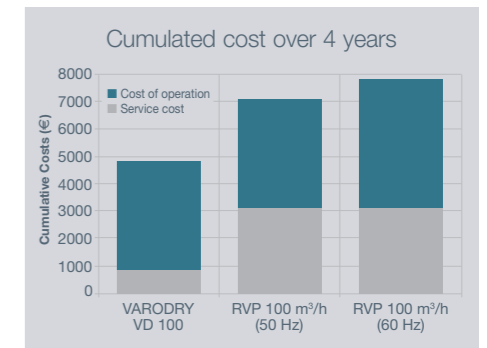
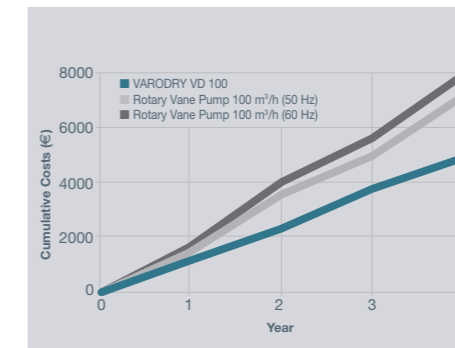

Compared with an oil-sealed rotary vane pump the VARODRY will save >600 EUR operating costs per year!

*“VARODRY – the easy, efficient, reliable and dry solution for your processes!”*

Uwe Zöllig, Business Development Manager Industrial Vacuum

### User Maintenance

The belt can easily be exchanged in less than 30 minutes. The exchange interval depends on the individual application but is typically >1 year. Belt-exchange kits and maintenance tool sets are available.

### VARODRY reduces your maintenance and service requirements

With only two wearing parts (belt and bearings), only minimal efforts are required to keep your pump running at peak performance – and improve the uptime at your facility.

### Leybold Service

The bearings can be exchanged on site by trained Service technicians. Typical bearing lifetime is >3 years. Complete pump-overhauls can be done in one of the many Leybold Global Service hubs.

To ensure highest factory uptime, Leybold offers fastest “pump exchange”. Our back-up pools also offer flat rates for exchanging pumps, thus your production keeps running at all times.

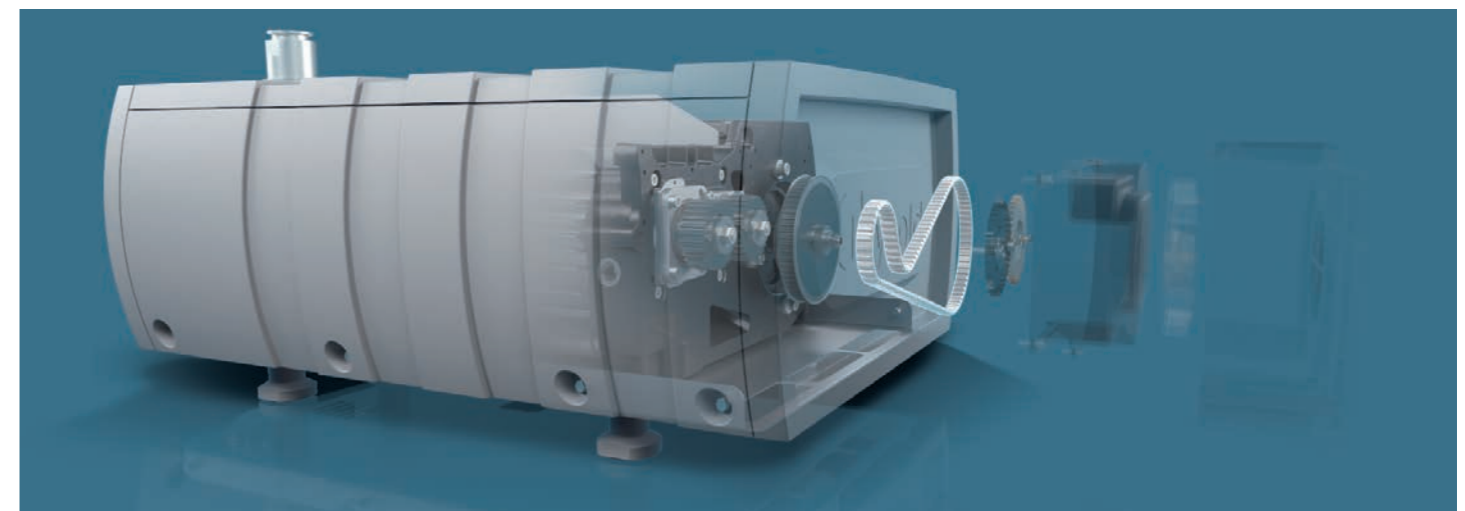

# Technical Data

## Ordering Information

### Ordering Information

Cat.-No.	VD 65	VD 100
50 Hz	111065V10	111100V10
50 Hz, with purge gas module	111065V15	111100V15
60 Hz	111065V11	111100V11
60 Hz, with purge gas module	111065V16	111100V16

See accessories for alternate connection options

### Dimensions

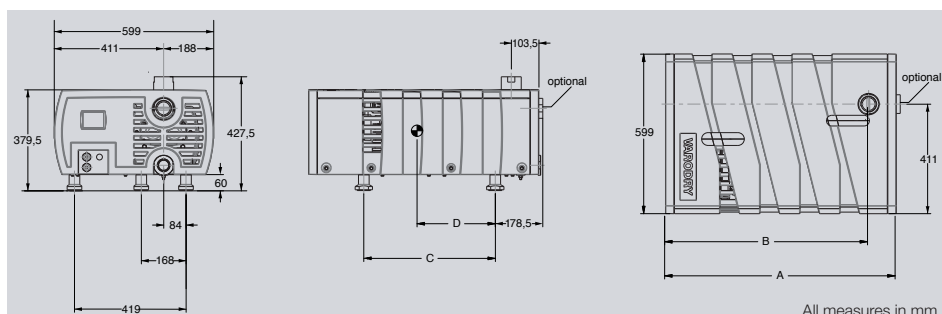

Pump Type	A	B	C	D
VD 65	773	670	402	253
VD 100	865	762	494	294

### Accessories

	Cat.-No.
Inlet Adapter DN40 ISO-KF, 20 mm	111005A20
Inlet Adapter G 1 1/4", 10 mm	111005A21
Inlet Adapter NPT 1 1/4 -11,5, 10 mm	111005A22
Inlet Adapter NPT 2-11,5, 35 mm	111005A23
Inlet Adapter DN63 ISO-K, 27 mm	111005A24
Exhaust Adapter DN40 ISO-KF, 20 mm	111005A30
Exhaust Adapter NPT 1 1/2-11,5, 30 mm	111005A31
Inlet non return valve (for inlet pressures >5 mbar) G 2"	111005A15

### Technical Data

VARODRY		VD 65	VD 100
Max. pumping speed	m <sup>3</sup> /h	65	100
Ultimate pressure			
without gas ballast	mbar	< 0.01	
with standard gas ballast	mbar	< 0.1	
Max. permissible inlet pressure	mbar	1050	
Max. permissible outlet pressure (rel. to ambient)	mbar	200	
Water vapor tolerance			
with standard gas ballast	mbar	20	
with big gas ballast	mbar	60	
Water vapor capacity			
with standard gas ballast	kg/h	0.6	1
with big gas ballast	kg/h	1.8	3
Noise level (with built-in silencer) at ultimate pressure (50 / 60 Hz)*	dB(A)	61 / 64	62 / 65
Permissible ambient temperature	°C	0 to +40	
Mains voltage		50 Hz, 200/400 V ±10%, 3 ph or 60 Hz, 230/460 V ±10%, 3 ph	
Rated motor power	kW	1.5	2.2
Protection class		IP55	
Intake connection		G 2"	
Outlet connection		G 1 1/2"	
Weight, approx.	kg	90	100

All listed data are preliminary.

\*According to DIN EN ISO 2151



Leybold GmbH  
 Bonner Str. 498 · D-50968 Cologne  
 T +49 (0) 221-347-0  
 varodry@leybold.com  
 www.leybold.com  
 www.varodry.com

**Pioneering products.  
 Passionately applied.**