



TURBOVAC iX Turbomolecular Pumps

90 l/s - 450 l/s



Discover new dimensions

With TURBOVAC iX, highest functionality meets outstanding performance. Our iX turbomolecular pump range with integrated vacuum system controller provides many features that have, until now, only been available in costly external pump control units: forevacuum pumps, gauges, coolers, valves and many other accessories can now be easily controlled via the turbo pump.

Designed to offer the best performance to size ratio in the ISO 63, 100 and 160 size range, TURBOVAC iX features a cutting edge rotor and drag stage design, leading to high performance and unparalleled speed especially for light gases.

A wide selection of interface options, housing and flange configurations as well as accessories completes this product line. The unique oil free hybrid bearing system with lifetime-lubricated ball bearings will boost your productivity and reduce cost of ownership.

Advantages at a glance

- **Price & Performance:** Best performance for your investment
- **Flexible & Fast:** High level of product flexibility – a perfect match for your application requirements
- **Plug & Play:** Simple and easy installation, operation and control thanks to flexible product design, integrated electronics and wide range of communication interfaces
- **Fit & Forget:** Superior reliability due to an innovative pump design and the unique oil-free hybrid bearing concept with lifetime-lubricated ball bearings available in the market today

Typical applications

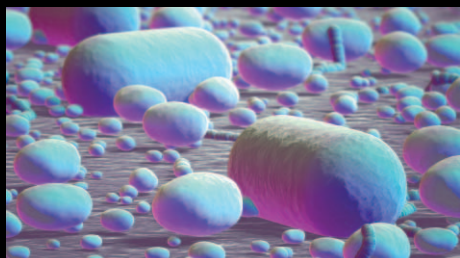

Analytical technologies/ Research & Development

- Mass spectrometry
- Electron microscopy
- Surface analysis
- X-ray analysis
- Particle accelerators and synchrotrons
- Laboratory coating systems
- MBE (Molecular Beam Epitaxy)
- UHV systems

Life Sciences

- Proton therapy
- Gamma sterilization
- Production of high quality implants

Industrial and coating applications

- PVD (Physical Vapour Deposition)
 - Optical coatings
 - CD/DVD/Blu-Ray disc production
 - Thin film technologies, photovoltaics
- Load locks, transfer chambers, handling systems
- Electron beam welders
- Insulation vacuum and leak detection



Performance you can rely on

Thanks to its variable rotor and drag stage design, the new TURBOVAC iX line provides the right performance for many different processes: for UHV applications and compact pump system solutions, TURBOVAC iX is the perfect choice. With a light gas pumping speed of up to 60 % above current reference products and compression values around 100 times higher than previous generation products, TURBOVAC iX is especially suited to be operated with small backing pumps. Also when it comes to demanding process and high gas throughput applications, TURBOVAC T iX models deliver unequaled efficiency with faster run up times, higher tolerance for particles and increased gas throughput.

Superior reliability

The unique oil free hybrid bearing system is characterized by its extreme reliability and durability.

This is achieved by an integrated lifetime lubrication system that never needs an oil change.

The special shaft and bearing system results in a low vibration pump design which reduces noise, mechanical stress and negative impact on vibration sensitive applications. Optimized cooling of the bearings is ensured through thermal isolation and a highly efficient motor. In addition, the pump is equipped with a purge port that protects the bearings from critical gases and particles. As a result, the up-time and lifespan of the pump as well as your productivity are increased considerably. In combination with low costs of ownership, your vacuum system will be more efficient than ever.



Countless options

In order to reach the highest possible level of comfort for installation, operation and control, TURBOVAC iX offers an integrated electronic drive with 24/48 V DC supply as well as an integrated vacuum system controller for extended functions and pump system control. The vacuum system controller features USB and digital I/O interfaces and an additional Anybus port that can be equipped with further interfaces available on the market (RS485, RS232, Profibus and many more). It is fitted with 3 accessory ports to control air cooling units and venting / purge valves as well as relay boxes for operation of a forevacuum pump, a flange heater or other accessories. For optimum flexibility, TURBOVAC iX provides unique features like a gauge port for gauge supply and pressure data acquisition. The pressure data can directly be used for the control of the pump system.

TURBOVAC iX is equipped with a rotatable forevacuum flange connection and optional available with housings with an additional interstage port that will allow you to pump down a second gas volume. These options and advantages make TURBOVAC iX a very cost-efficient solution for basic vacuum system control and a more than competitive alternative to costly external control units.

A flexible and comprehensive accessory program completes the new product range. This includes economic power supplies for 100-240V mains supply, adjustable air or water cooling units, heaters, venting and purge accessories as well as installation and mounting kits to simplify pump installation. Discover infinite possibilities with the flexibility of TURBOVAC iX!



More in it for you ...

Performance

- Industry-leading pumping speed especially for light gases (up to 60 % higher than existing products)
- Optimized rotor diameter for ISO 63, 100 and 160 flanges to provide maximum pumping performance

Flexibility

- Vacuum port design flexibility
 - Rotatable fore-vacuum port
 - Interstage port options
- Variable rotor and drag stage configurations for perfect match to application requirements

Installation, operation and control

- Integrated 24/48V DC drive electronics to avoid expensive cabling
- Integrated vacuum system controller for plug & play pump system control
 - Standard USB and 15-pin digital I/O
 - Optional RS 485, RS232, Profibus, and more
 - Control of up to 6 accessories
 - Gauge port for gauge supply and pressure data acquisition
 - Forevacuum pump control
- Highly efficient motor
- Thermal isolation by design for optimized cooling of bearing and improved pump lifetime
- Special shaft and bearing design reduces vibration
- Maintenance-free upper passive magnetic bearing
- Oil free, lifetime lubricated lower mechanical ceramic ball bearing, field-replaceable



... get more out of it



Best performance for your investment

- Flexible performance adaptation – tailor-made to perfectly meet your requirements
- Outstanding performance for all applications thanks to innovative technology

Easy installation, operation and control

- Plug & Play: integrated electronics and vacuum system controller, communication options and flexible accessories
- Installation in any orientation

Increased productivity and system uptime at lowest cost

- Superior reliability due to innovative pump and bearing design
- Fit & Forget: first and only mechanical turbomolecular pump with oil-free hybrid bearing concept and maintenance-free ball bearings – no need for oil changes
- Possibility of bearing replacement on-site

Technical specifications

TURBOVAC 90 iX

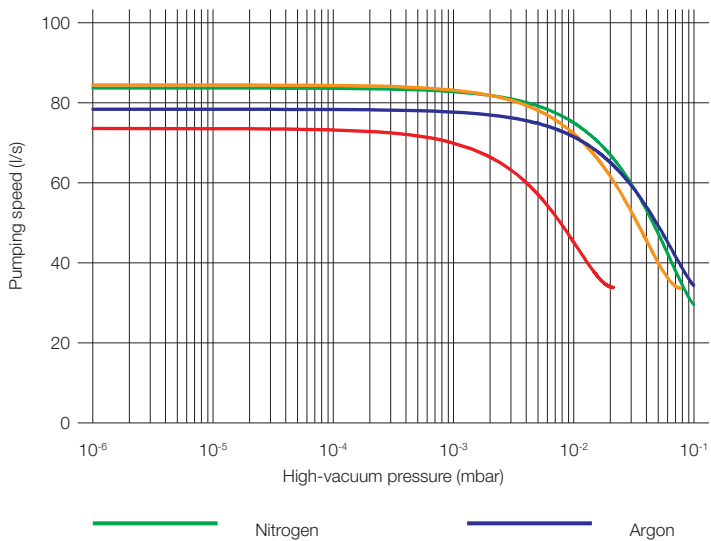

TURBOVAC 250 iX

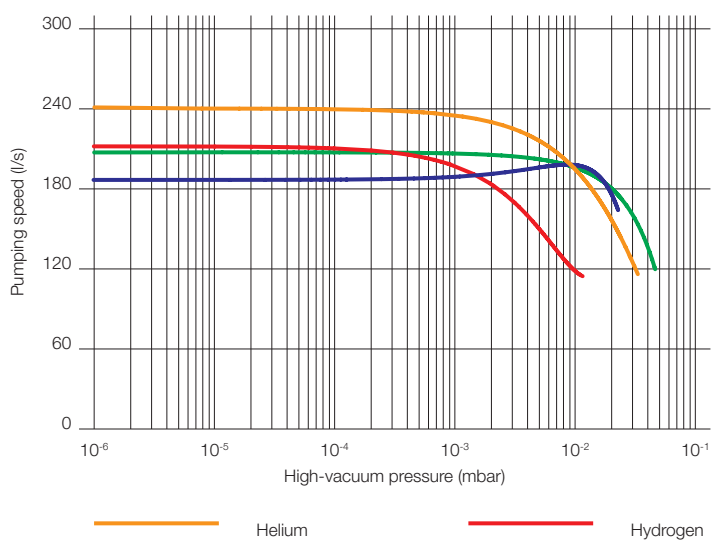

TURBOVAC 90 iX

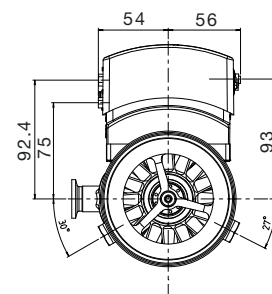
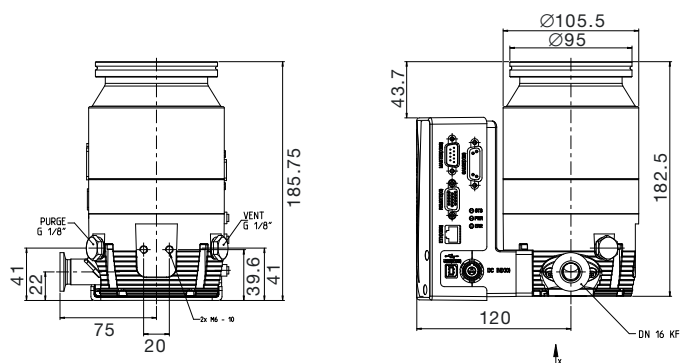

	h
TURBOVAC 90 iX	
DN 63 ISO-K	186
DN 63 CF	203

TURBOVAC 250 iX

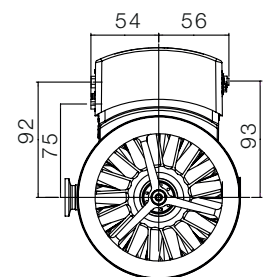
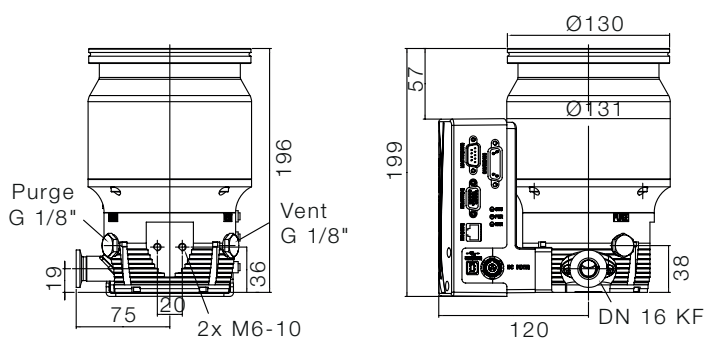

	h
TURBOVAC 250 iX	
DN 100 ISO-K	199
DN 100 CF	208

TURBOVAC 350 iX

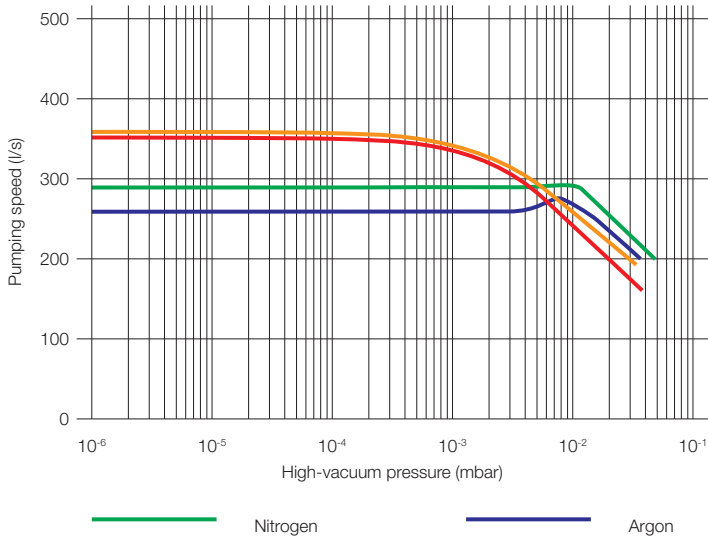

TURBOVAC 450 iX

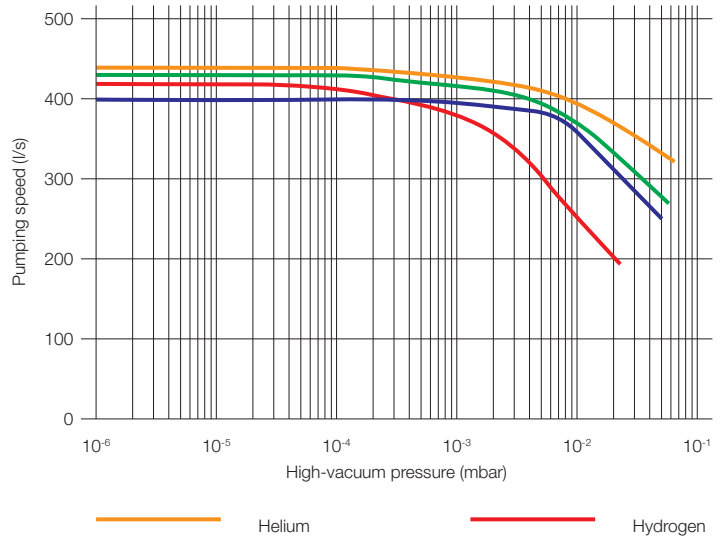

TURBOVAC (T) 350 iX

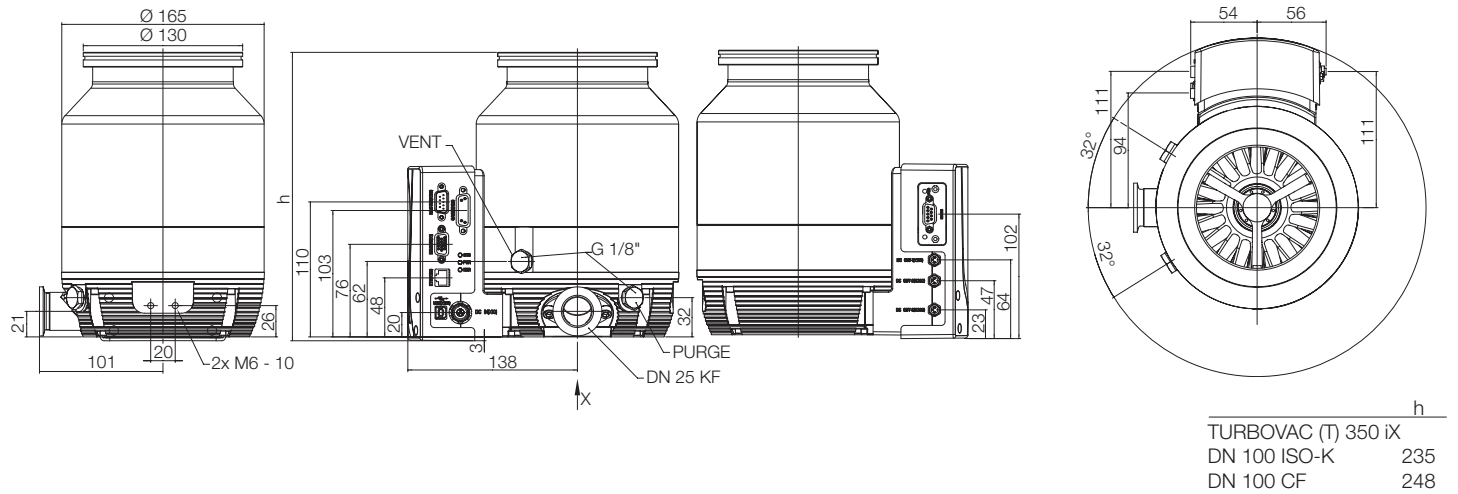

TURBOVAC (T) 450 iX

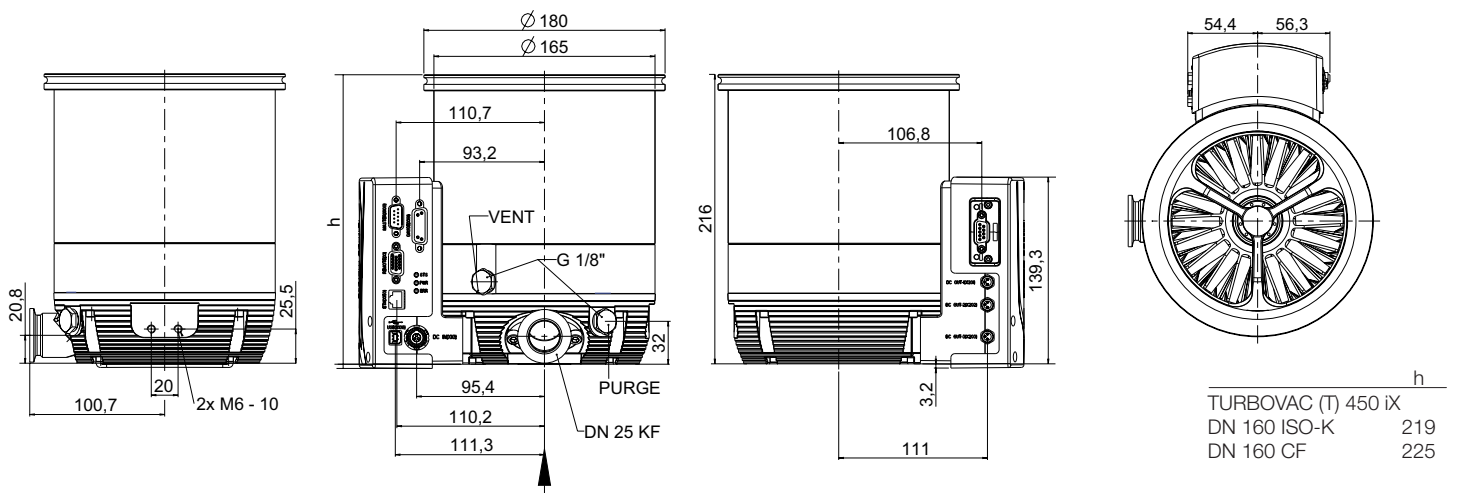

Technical specifications

Technical data			
TURBOVAC		90 iX	250 iX
High-vacuum connection	DN	63 ISO-K 63 CF	100 ISO-K 100 CF
Fore-vacuum connection	DN	16 KF	16 KF
Pumping speed for	$l \cdot s^{-1}$		
N ₂		90	225
Ar		83	210
He		90	250
H ₂		78	200
Gas throughput	$mbar \cdot l \cdot s^{-1}$		
N ₂		10	6
Ar		3	3
He		11	6
H ₂		11	> 10
Compression ratio			
N ₂		$1 \cdot 10^{11}$	$1 \cdot 10^{11}$
Ar		$1 \cdot 10^{11}$	$1 \cdot 10^{11}$
He		–	–
H ₂		$5 \cdot 10^7$	$2 \cdot 10^7$
Ultimate pressure ISO-K/CF with 2-stage oil-sealed rotary vane pump	mbar	$\leq 8 \cdot 10^{-8} / 5 \cdot 10^{-10}$	
Max. permissible fore-vacuum pressure for N ₂	mbar	14	14
Operating speed	rpm	72 000	
Cooling standard		Convection	
Cooling optional		Air or water	
Weight ISO-K/CF	kg	3.6 / 5.3	4.5 / 7.1
Recommended fore-vacuum pumps	TRIVAC SCROLLVAC DIVAC	D 2,5 E / D 4 B SC 5 D 1.4 HV3	D 2,5 E / D 4 B SC 5 D / SC 15 D 3.8 HV3
Supply voltage		24/48V DC $\pm 10\%$	
Max. current consumption		10 A at 24 V DC	
Max. power consumption	W	240	
Interfaces		USB, 15 pin digital I/O, Anybus Optional RS485, RS232, Profibus (additional on request)	

Technical data

TURBOVAC		350 iX	450 iX	T 350 iX	T 450 iX
High-vacuum connection	DN	100 ISO-K 100 CF	160 ISO-K 160 CF	100 ISO-K 100 CF	160 ISO-K 160 CF
Forevacuum connection	DN	25 KF	25 KF	25 KF	25 KF
Pumping speed for	$l \cdot s^{-1}$				
N ₂		290	430	290	430
Ar		260	400	260	400
He		360	440	360	440
H ₂		350	420	320	400
Gas throughput	$mbar \cdot l \cdot s^{-1}$				
N ₂		4.5	4.5	11.5	11.5
Ar		2.0	2.0	6.0	6.0
He		8.0	8.0	20.0	20.0
H ₂		8.0	8.0	20.0	20.0
Compression ratio					
N ₂		$1 \cdot 10^{11}$	$1 \cdot 10^{11}$	$1 \cdot 10^{10}$	$1 \cdot 10^{10}$
Ar		$1 \cdot 10^{11}$	$1 \cdot 10^{11}$	$1 \cdot 10^{11}$	$1 \cdot 10^{11}$
He		$1 \cdot 10^8$	$1 \cdot 10^8$	$1 \cdot 10^6$	$1 \cdot 10^6$
H ₂		$1 \cdot 10^6$	$1 \cdot 10^6$	$1 \cdot 10^4$	$1 \cdot 10^4$
Ultimate pressure ISO-K/CF with 2-stage oil-sealed rotary vane pump	mbar	$\leq 8 \cdot 10^{-8} / 5 \cdot 10^{-10}$			
Max. permissible forevacuum pressure for N2	mbar	10	10	0.5	0.5
Operating speed	rpm	60,000			
Cooling standard		Convection			
Cooling optional		Air or water			
Weight ISO-K/CF	kg	8.0/12.0	8.2/13.0	7.5/11.5	7.7/12.5
Recommended forevacuum pumps	TRIVAC	D 4 B	D 4 B	D 16 B	D 16 B
	SCROLLVAC	SC 5 D	SC 5 D	SC 15 D	SC 15 D
		SC 15 D	SC 15 D	SC 30 D	SC 30 D
	DIVAC	3.8 HV3	3.8 HV3	-	-
Supply voltage		24/48V DC \pm 10 %			
Max. current consumption		10A at 24V DC			
Max. power consumption	W	240			
Interfaces		USB, 15 pin digital I/O, Anybus Optional RS485, RS232, Profibus (additional on request)			

Order information

For operating a TURBOVAC iX, a suitable forevacuum pump, a power supply as well as a DC/mains cable are mandatory. Further accessories might be required depending on the application and operating conditions.

Pumps

TURBOVAC	90 iX	250 iX	350 iX	450 iX	T 350 iX	T 450 iX
High-vacuum flange	63 ISO-K	100 ISO-K	100 ISO-K	160 ISO-K	100 ISO-K	160 ISO-K
Part Number *)	810031V3300	820051V3300	830051V3300	830071V3300	830050V3300	830070V3300
High-vacuum flange	63 CF	100 CF	100 CF	160 CF	100 CF	160 CF
Part Number *)	810041V3300	820061V3300	830061V3300	830081V3300	830060V3300	830080V3300

* all part numbers with USB+, 15 pin digital I/O and RS485 interface; other interfaces upon request

Accessories

Power supply, cables and accessories

- 800100V0003 – **TURBO.POWER integra incl. cable 0.3 m**
- 800096V0100 – Cable TURBOVAC i – TURBO.POWER integra, 1 m
- 800096V0300 – Cable TURBOVAC i – TURBO.POWER integra, 3 m
- 800096V0500 – Cable TURBOVAC i – TURBO.POWER integra, 5 m
- 800102V0002 – Mains cable for power supplies, 3 m, EC plug
- 800102V0003 – Mains cable for power supplies, 3 m, UK plug
- 800102V1002 – Mains cable for power supplies, 3 m, US plug
- 800110V0016 – Accessory cable TURBOVAC i, M8-M8, 2m
- 800110V0020 – Y cable TURBOVAC i, M8
- 800110V0021 – Start stop switch for TURBOVAC i
- 800110V0108 – USB cable 2.0 Type A/B, 1.8 m
- 230439V01 – **LEYASSIST software for turbomolecular pumps**
- 800110V0030 – **Relay box for forevacuum pump, 1-phase, 10A**
incl. 2 m M8-M8 cable

Cooling

- 800136V0007 – Air cooling radial TURBOVAC TURBOVAC 90 i(X)
- 800136V0009 – Air cooling radial TURBOVAC TURBOVAC 250 i(X)
- 800136V0005 – Air cooling radial TURBOVAC 350-450 i(X)
- 800136V0008 – Air cooling axial TURBOVAC 90 i(X) und 250 i(X)
- 800136V0006 – Air cooling axial TURBOVAC 350-450 i(X)
- 800135V0005 – Water cooling TURBOVAC i(X)
- 800135V0006 – Water cooling TURBOVAC i(X), G 1/4"

Heating

- 800137V0003 – Flange heating DN 63 CF, 230 V
- 800137V0004 – Flange heating DN 63 CF, 115 V
- 800137V0005 – Flange heating DN 100 CF, 230V
- 800137V0006 – Flange heating DN 100 CF, 115V
- 800137V0007 – Flange heating DN 160 CF, 230V
- 800137V0008 – Flange heating DN 160 CF, 115V

Venting and Purge

- 800120V0012 – Venting valve, 24 V DC, G 1/8"
- 800120V0013 – Purge gas valve, 24V DC, 24 sccm, G 1/8"
- 800120V0014 – Purge gas throttle, 24 sccm, G 1/8"
- 800120V0022 – Power failure venting valve, 24V DC, G 1/8"
- 800110V0022 – Air filter, G 1/8"



Leybold GmbH
Bonner Str. 498 · D-50968 Köln
T +49 (0) 221-347-0
F +49 (0) 221-347-1250
info@leybold.com

www.leybold.com

